

Cylinder 6 stage front end with spherical eye

CD19TS6310535NA61102

CUSTOMER TO FIT
1 X 1/8" NIPPLE
FOR GREASING
NG5 OR NG6

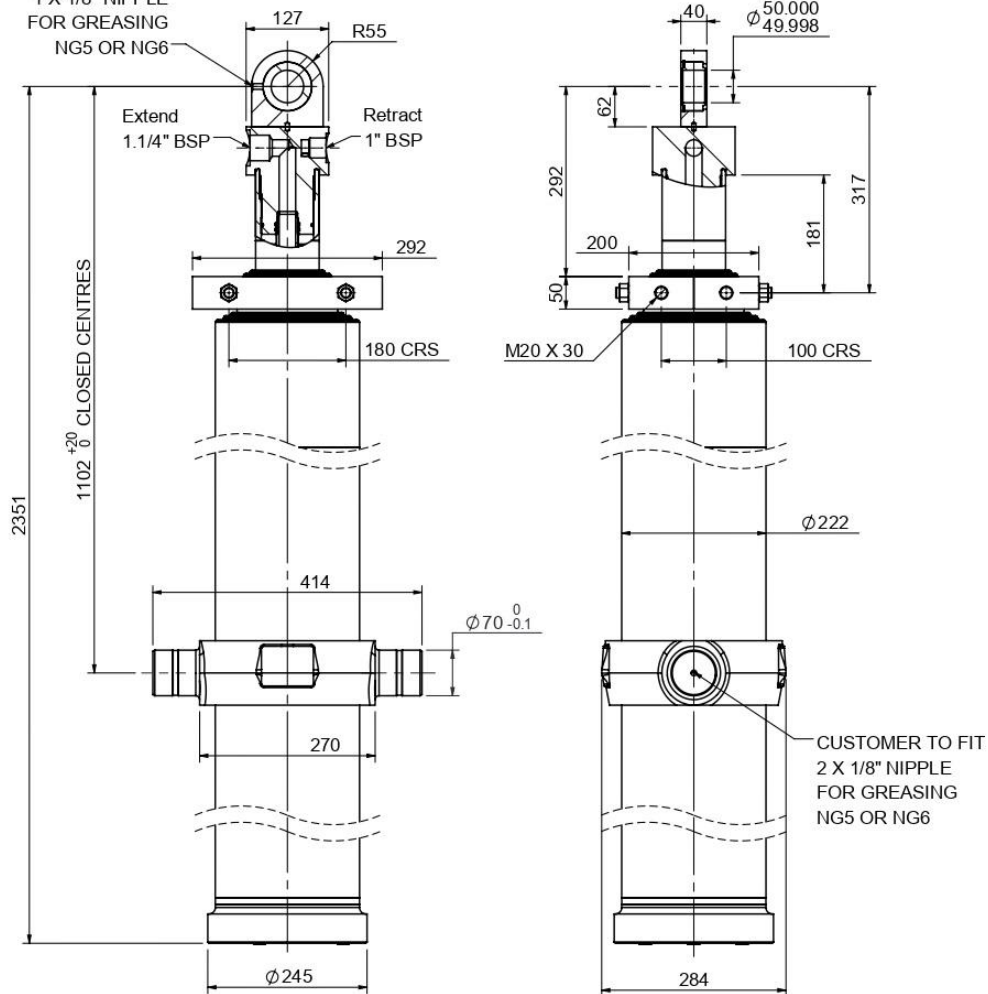

INNER TUBES HARD CHROMED

SPECIFICATION

Stage	Tube Diameter	Tube Bore	Length	Stroke	Swept Volume (Extend)	Swept Volume (Retract)
Base	222	206	1993	-	-	-
1	198	184	1954	1705	56.8	4.3
2	176	163	1954	1715	45.6	3.9
3	155	144	2004	1725	36.0	3.4
4	136	125	2004	1785	29.1	3.1
5	116	106	2004	1800	22.1	2.8
6	98	87	2154	1805	15.9	2.3
Total (+5/-10)				10535	mm	
Final stroke reduced by				0	mm	
Swept Vol (Extend)				205.5	Litres	
Swept Vol (Retract)				19.8	Litres	
Maximum Pressure				190	Bar	
Operating Pressure				190	Bar	
Cylinder Mass				401	Kg	
Stage	Thrust @ Max.Press		Thrust @ Op. Press			
	Extend	Retract	Extend	Retract		
1	64.6	4.9	64.6	4.9		
2	51.5	4.4	51.5	4.4		
3	40.4	3.9	40.4	3.9		
4	31.5	3.4	31.5	3.4		
5	23.8	3.3	23.8	3.3		
6	17.1	2.5	17.1	2.5		

NOTES

- This cylinder is intended for load ejection purposes only and should not be used for compacting.
- Cylinder is painted in primer to RAL5013.
- Refer to www.edbro.com for:
 - Bracket details
 - Installation instructions that must be observed
 - Correct oil selection
 - An explanation of ejection capacity