

PB BQ 625X680 DAF



Serbatoi olio idraulico
Hydraulic oil tanks
SCALETTA

Fam. BQ (625x680)
da/from 180 lt
a/to 210 lt

Questa gamma di serbatoi è stata appositamente studiata per l'installazione su trattori stradali DAF TRUCKS. I serbatoi sono stati progettati per essere installati al posto della scaletta di salita retrocabina originariamente installata sui veicoli e permettono di soddisfare l'esigenza di avere un serbatoio idraulico di notevole capacità, conservando sia il serbatoio gasolio originale che la ruota di scorta (oppure serbatoio gasolio supplementare).

This range of tanks has been specific studied for the installation on road tractors manufactured by DAF TRUCKS. The tanks have been projected to be fitted to the place of the side ladder, to climb rear the cab, originally installed on the vehicles allowing to satisfy the demand to have an hydraulic tank of notable capacity as well as preserving the main original fuel tank and both the spare wheel (or the additional fuel tank).



ALLUMINIO ALUMINIUM				
Capacità nominale Filling capacity	Codice serbatoio Tank code	A	Peso Weight	Veicolo Vehicle
			Kg	
200	H2ALBQ05522	550	45	CF - XF OLD
200	H1ALBQ05520	550	45	XF - XG - XG PLUS NEW GENERATION

Ingombro serbatoio / Tank dimensions

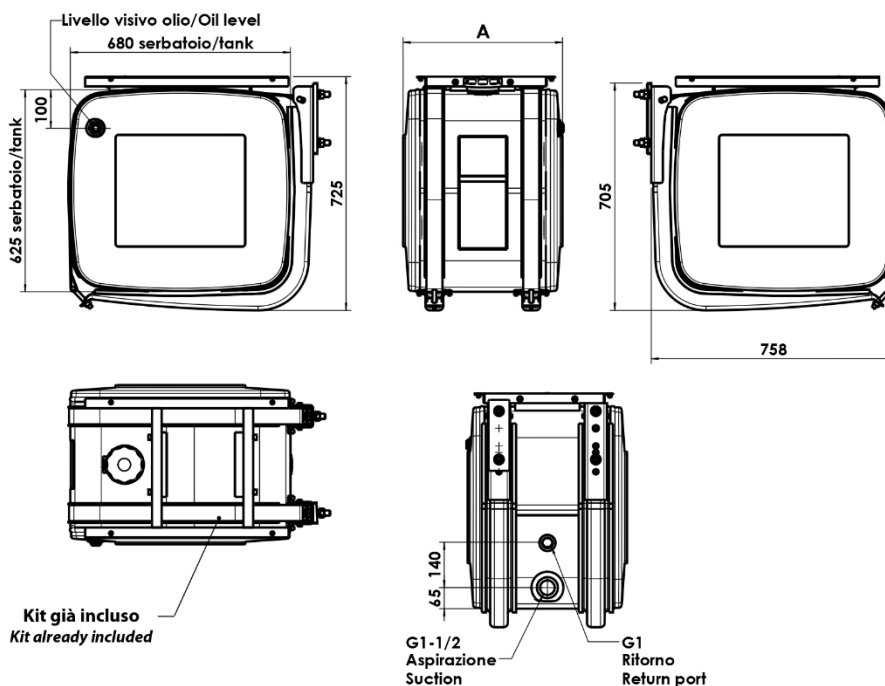

PB BQ 625X680 DAF



Serbatoi olio idraulico
Hydraulic oil tanks
SCALETTA

Fam. BQ (625x680)
da/from 180 lt
a/to 210 lt

Serbatoio appositamente realizzato da **OMFB per veicoli DAF**. Viene montato sul lato sinistro a ore 10, al posto della scaletta (non è possibile quindi montare la passatoia). Per questo, è necessaria la carenatura laterale in cui sono presenti i gradini. Costruito con le più moderne tecnologie, garantisce la massima affidabilità e durata nel tempo, oltre che un aspetto esteriore perfettamente integrabile sui moderni trattori stradali. La gamma di accessori rende il suo impiego particolarmente flessibile.

Oil tank especially designed by OMFB for DAF trucks. It is fitted on the left-hand side, 10 o'clock position instead of the stepladder (therefore it is not possible to mount the metal grid). For this reason it is necessary to get side skirt kit with built-in steps.

Based on the latest technology, these aluminium tanks are produced to ensure maximum reliability and longer lifetime as well as an exterior aspect that can be perfectly integrated. High versatility is granted by a wide choice of available accessories.



ALLUMINIO ALUMINIUM					
Capacità nominale Filling capacity	Codice serbatoio + kit Tank code + kit	A	Peso Weight	Codice kit Kit code	Peso Weight
			Kg		Kg
210	13565302101	520	49	135903BQLX0	26

Ingombro serbatoio / Tank dimensions

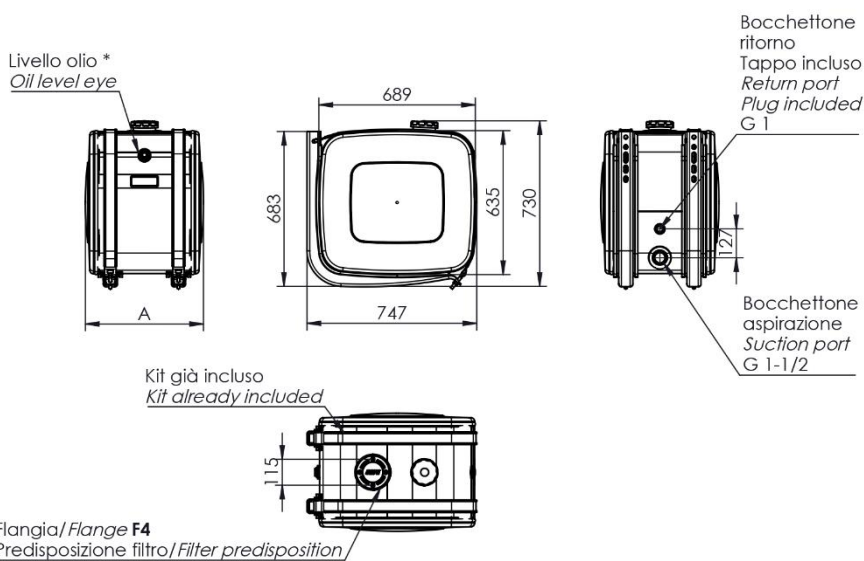

Ricambi / Spare parts	
	R1+R2 135990BQ1X0 Fascia inox + guaina EPDM fissaggio serbatoi Stainless steel strap + Protection EPDM for tank
	R2 50620001001 Guaina EDPM fascia Protection for oil tank strap
	R3 50620000803 Antivibrante - Protection
	R4 53800404397 Piastra rinforzo Reinforcement plate
	R5 538205BQLGD Staffe supporto Mounting brackets
	R6 13590105125 Kit viti e dadi fissaggio supporti Screws and nuts kit

11801300201 : TAPPO DI RIEMPIMENTO / FILLER CAP

Già compreso nel serbatoio. Solo per ricambi
Already included with the tank. Only for spare part

