

PB 02802500173



**PRESA DI FORZA A
COMANDO PNEUMATICO**

PNEUMATIC CLUTCH POWER TAKE-OFF

CODICE PTO
PTO CODE

28-25

CAMBIO
GEARBOX

SCANIA



DIAGRAMMA DI UTILIZZO
WORKING CONDITION

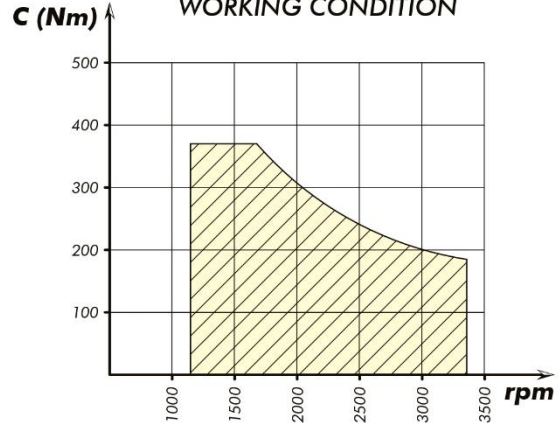

Interruttore segnalazione PTO inserita / PTO pressure signal switch

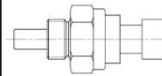

PACKARD
311-001-00116

OPTIONAL**
Da ordinare separatamente
To be ordered separately

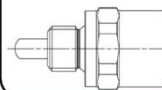

DIN 72585
311-001-00205

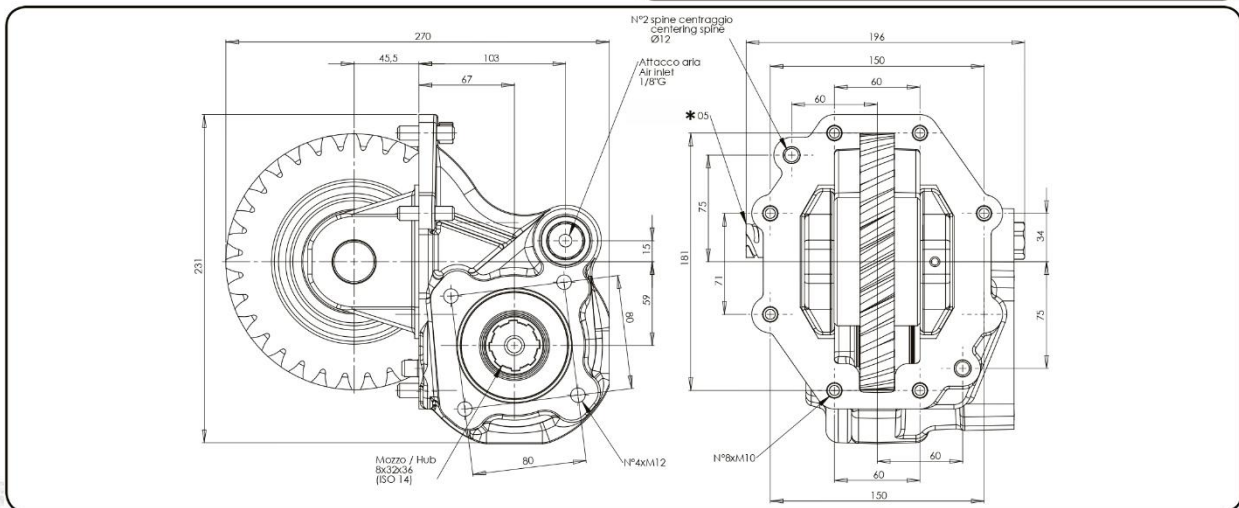

Tipo cambio Gearbox	Codice PTO PTO code	Versione Version	Giri pto a 1000 giri motore Pto ratio@1000 eng.rpm		Coppia massima Max torque	Lato montaggio Mounting side	Uscita Output	Rotazione Rotation	Kit di montaggio Mounting kit	Peso Weight
			NORM.	VEL.						
GRSO 905 GRSO 925	28-25-173	17	1680	2105	370	Dx Right	Poster. Rear	Oraria Cw	154-3-3571	18,5